

Problem 1 (25%)

Consider the structural system shown in the figure. The beam AB is a standard 0.5-m I-beam with a mass of 95 kg per meter of length.

- (a) Determine the magnitude T of the tension in the supporting cable. (**Hint:** only one equation is needed to obtain this cable force) (15%)
- (b) Determine the magnitude of the force on the pin at A . (10%)

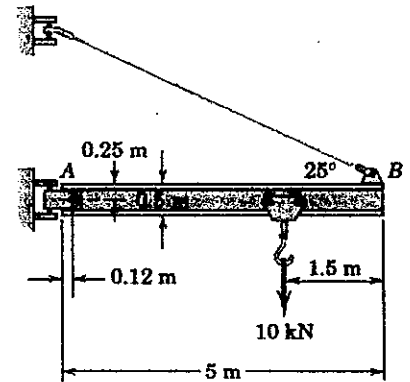

Problem 2 (25%)

Determine the geometrical properties of the shaded area shown in the figure.

- (a) Calculate the shaded area A . (10%)
- (b) Locate the centroid of the shaded area. (**Hint:** both x - and y -coordinates should be presented) (15%)

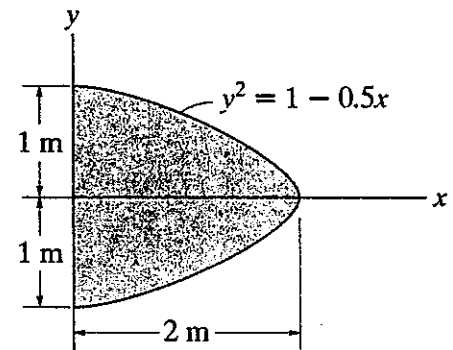

Problem 3 (25%)

At the instant shown in the figure, the bicyclist at A is traveling at 7 m/sec around the curve on the race track while increasing his speed at 0.5 m/sec^2 . The bicyclist at B is traveling at 8.5 m/sec along the straight-a-way and increasing his speed at 0.7 m/sec^2 .

- (a) Determine the relative velocity of A with respect to B . (**Hint:** find the vector $\mathbf{v}_{A/B}$) (10%)
- (b) Determine the relative acceleration of A with respect to B . (**Hint:** find the vector $\mathbf{a}_{A/B}$) (15%)

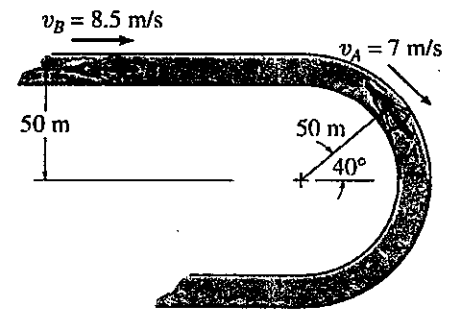

Problem 4 (25%)

The uniform crate has a mass of 100 kg and rests on the cart having an inclined surface, as shown in the figure. The coefficient of static friction between the crate and the cart is $\mu_s = 0.5$.

- (a) Will the crate tip or slip? (5%)
- (b) Determine the normal force from the inclined surface to the crate. (10%)
- (c) What is the magnitude of the smallest acceleration? (10%)

