

國立中山大學100學年度碩士班招生考試試題

科目：電子學【電機系碩士班甲組、乙組、戊組】

1. (25%) Consider a source follower such as that in Fig. 1 Specifically,
 - (a) Please derive R_{in} , A_{vo} , A_v and R_o with r_o taken into account. (4*5%)
 - (b) Please derive the overall small-signal voltage gain G_v with r_o taken into account. (1*5%)

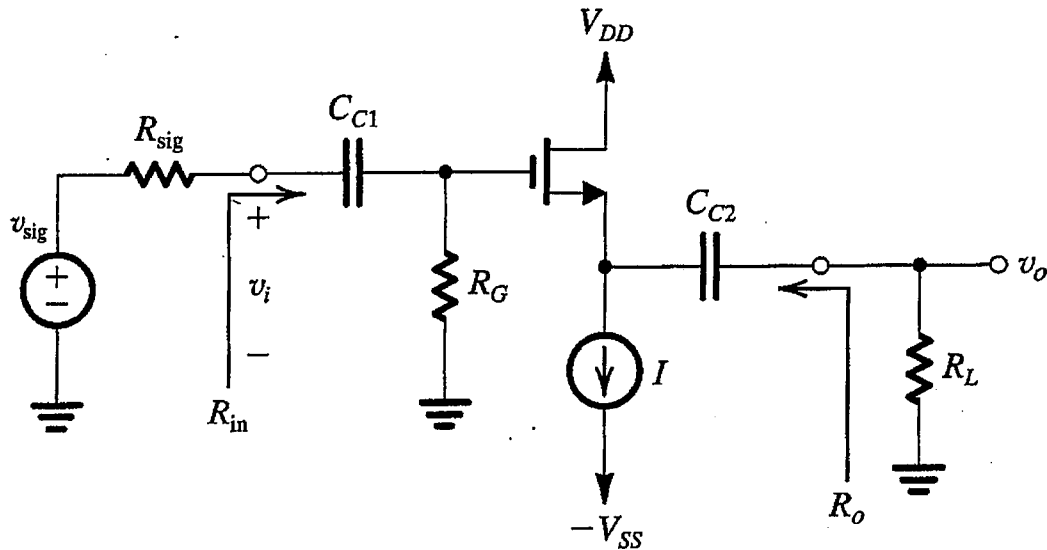

Fig. 1

2. (20%) Please find the three break frequencies and the low $3dB$ frequency of the common emitter amplifier with an emitter resistance as shown in Fig. 2. (4*5%)

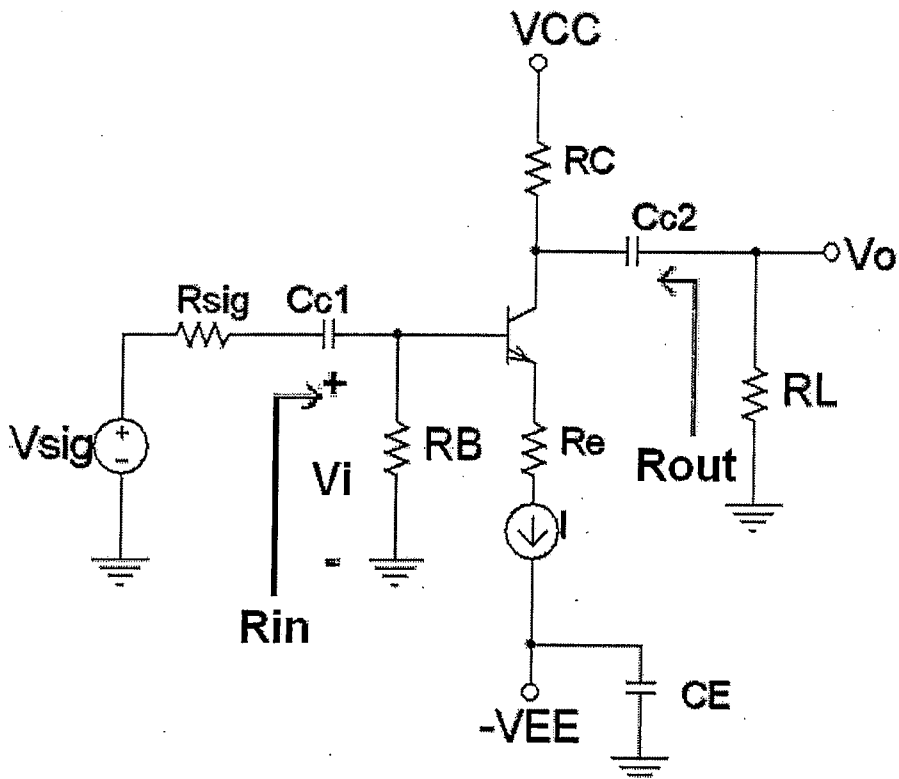

Fig. 2

國立中山大學100學年度碩士班招生考試試題

科目：電子學【電機系碩士班甲組、乙組、戊組】

3. (20%) Design and draw a three input CMOS NAND and CMOS NOR gates respectively. Also, please find out the $(W/L)_P/(W/L)_N$ ratios of the designed CMOS NAND and CMOS NOR gates respectively so that their PMOS part and NMOS part have same MOS transconductance parameters, where W/L is aspect ratio.

(2*5%, 1*10%)

4. (15%) In Fig. 4, give that the input resistance is 10 KΩ and the differential voltage gain is 100, please find out (a) $R_1 = R_3 = ?$, and (b) $R_2 = R_4 = ?$ (2*7.5%)

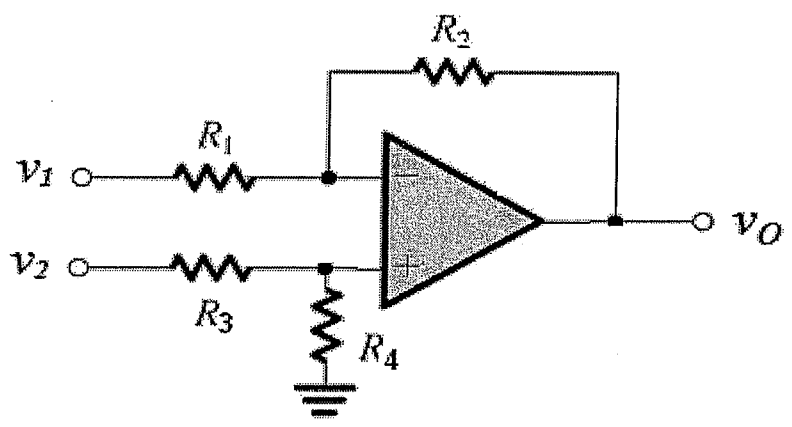

Fig. 4

5. (20%) Fig. 5 shows an operation amplifier and its small equivalent circuit. Please derive its output resistance R_o and its dc open-loop gain A_v , with respect to the circuit transistor's g_m and r_o .

(2*10%)

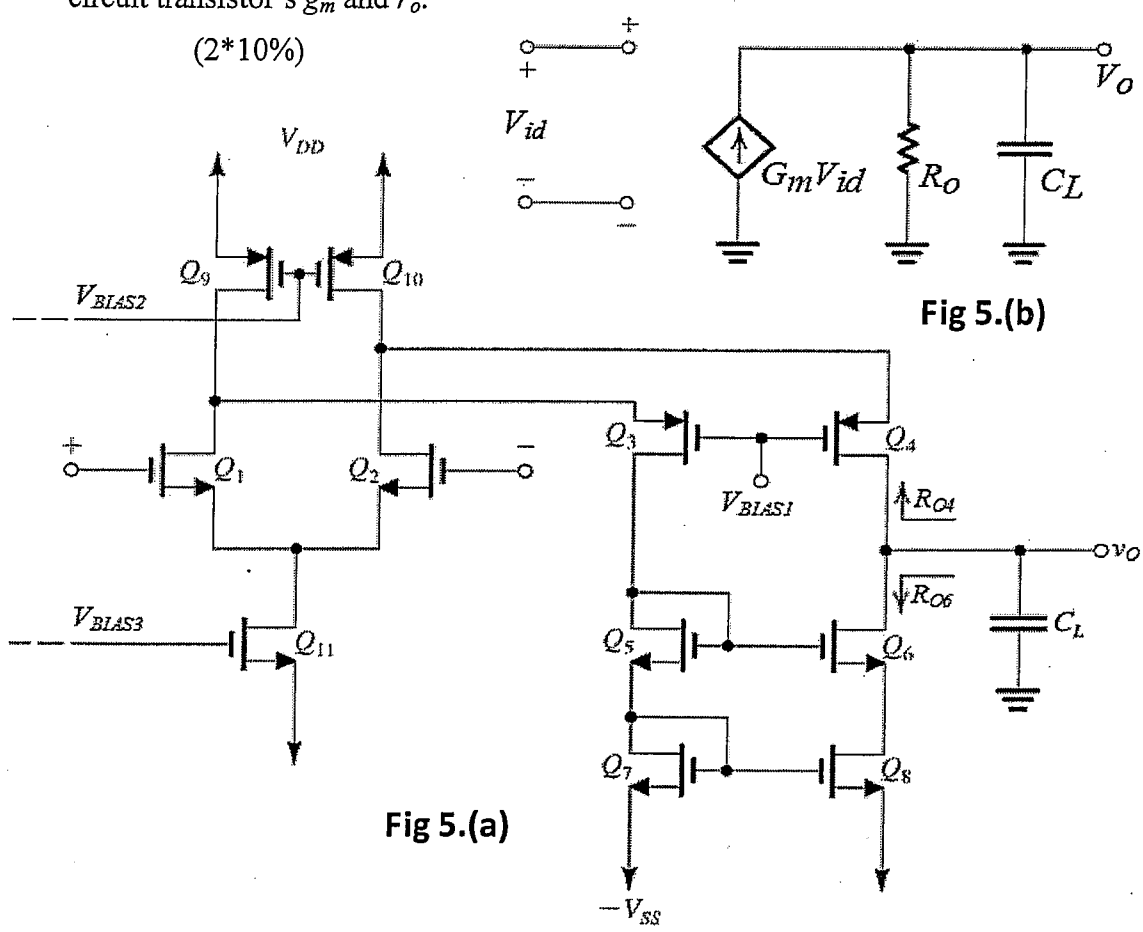

Fig 5.(a)

Fig 5.(b)