

考試科目	程式設計與 資料結構	所別	數位內容碩士學位學程/ 資訊技術組	考試時間	2月27日(日)第四節
------	---------------	----	----------------------	------	-------------

1. (10%)

A logical expression contains three types of operators, namely, in order of precedence, \sim (not), \wedge (and), \vee (or).

Given a logical expression, $A \vee (B \wedge (C \sim D \vee E)) \wedge (F \vee G)$

(1) Please write its prefix form.

(2) Please draw its expression tree.

2. (10%)

Given an n -node binary search tree using array implementation, please give

(1) the smallest possible position, and

(2) the largest possible position

in this array for the smallest element and the largest element of this binary search tree respectively.

3. (10%)

(1) Please show the result of sorting 64, 16, 9, 316, 56, 27, 35, 136, using radix sort with 7 buckets. Please list the result of each pass.

(2) Please show that the time complexity of radix sorting of n keys with r buckets.

4. (10%)

Given an undirected graph shown in Figure 1, to find the shortest path from A to every other vertex, Dijkstra's algorithm proceeds in stages. At each stage, Dijkstra's algorithm selects a vertex, declares it to be known, and updates tentative distances for each vertex. The first stage selects the vertex A .

(1) Please show the vertex selected at stage 4 and stage 5 respectively.

(2) Please show the tentative distance of each vertex after stage 4 and stage 5 respectively.

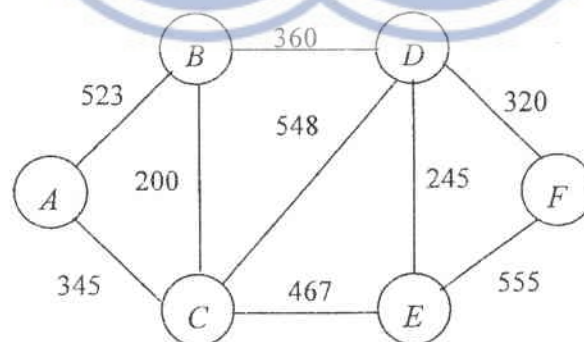

Figure 1.

請注意：背面還有試題。

考試科目	程式設計與資料結構	所別	數位內容碩士學位學程/ 資訊技術組	考試時間	2月27日(日)第四節
------	-----------	----	----------------------	------	-------------

5. (10%)

Given the two-dimension array shown in Table 1, after execution of the program segment in C Language shown in Figure 2, please indicate the result of

- (1) flag[2]
- (2) flag[5]
- (3) flag[6]
- (4) flag[8], respectively.

```

void Mystery( void )
{
    int i, count, flag[n];
    for ( i = 0; i < n; i++ ) {
        flag[ i ] = 0;
    }
    count = 0;
    for ( i = 0; i < n; i++ )
        if ( flag[ i ] == 0 )
            Secret( i );
}
void Secret( int v )
{
    int i;
    flag[ v ] = count++;
    for ( i = 0; i < n; i++ )
        if ( data[ v ][ i ] == 1 && flag[ i ] == 0 ) {
            Secret( i );
        }
}
    
```

Figure 2.

	1	2	3	4	5	6	7	8
1	1	1	1	0	0	0	0	0
2	1	1	0	1	1	0	0	0
3	1	0	1	0	1	1	0	0
4	0	1	0	1	0	0	1	1
5	0	1	1	0	1	0	0	0
6	0	0	1	0	0	1	0	0
7	0	0	0	1	0	0	1	0
8	0	0	0	1	0	0	0	1

Table 1.

6. (10%)

There is a town with n citizens. Only some friendships between pairs of people are known. According to the famous saying that "The friends of my friends are my friends, too" it follows that if A and B are friends and B and C are friends then A and C are friends, too. Please write a procedure in a language of your choice (please specify) to determine the friendships for all pairs of citizens in $O(n^3)$.

7. (10%)

Given a network of n computers, the distance between each pair of computers is known and is shown in Table 2. Please design an $O(n^2 \log n)$ algorithm to find the shortest length of cable that can be used to connect all computers while ensuring that there is a path between any two computers. Please illustrate your algorithm by the example shown in Table 2.

考試科目	程式設計與 資料結構	所別	數位內容碩士學位學程/ 資訊技術組	考試時間	2 月 27 日(日) 第四節	
------	---------------	----	----------------------	------	-----------------	--

	1	2	3	4	5	6
1	0	6	3	4	10	8
2	6	0	15	10	2	5
3	3	15	0	6	4	2
4	4	10	6	0	4	3
5	10	2	4	4	0	1
6	8	5	2	3	1	0

Table 2.

8. (30%) True or False (Please use O for true, X for false)

- (1) It may take $O(1)$ time to insert a key into a given position in a linked list.
- (2) It may take $O(n+m)$ time to merge two sorted linked list of size n and m into one sorted linked list.
- (3) The third minimum element of a minimum heap must be one of the two children of the root.
- (4) If the input keys are strings, hashing doesn't work.
- (5) Extendible hashing is a dynamic hashing scheme.
- (6) Queue is more useful than stack for checking whether every right parenthesis correspond to its left counterpart in a statement of a program.
- (7) The recurrence relation of worst case time complexity in terms of comparison operations for quick sort of n records is $T(n)=2T(n/2)+cn$.
- (8) The worst case time complexity of searching a key in a sorted linked list of size n is $O(\log n)$
- (9) The worst time complexity of LR rotation in an AVL tree of size n is $O(1)$
- (10) The best time complexity of finding the maximum in an AVL tree of size n is $O(\log n)$
- (11) If all pairs of vertices are adjacent in an undirected graph, then this graph is connected.
- (12) Given a graph with n vertices, the minimum cost spanning tree of this graph contains exactly $n-1$ edges.
- (13) To represent the friendships of users in Facebook, adjacency matrix representation is more appropriate than adjacency list representation.
- (14) A topological ordering is not possible if all the in-degrees of vertices in the graph are nonzero.
- (15) Currently there are no algorithms in which finding the path from a single source to one vertex is any faster than finding the path from a single source to all vertices.