

國立交通大學 103 學年度碩士班考試入學試題

科目：工程力學(3052)

考試日期：103 年 2 月 15 日 第 2 節

系所班別：土木工程學系

組別：土木系甲組一般生

第 1 頁, 共 2 頁

【可使用計算機】\*作答前請先核對試題、答案卷(試卷)與准考證之所組別與考科是否相符!!

1. A column shown below will buckle under compression load.

(1) Please derive Euler buckling load of the fix-ended column. (20%)

(2) If  $A$  and  $B$  are immovable supports, what is the critical change of temperature at which the column will buckle? Please express the answer in terms of  $\alpha$ ,  $r$ , and  $L$ , where  $\alpha$  is thermal coefficient of the column,  $r$  is radius of gyration of the cross section, and  $L$  is the length of the column. (10%)

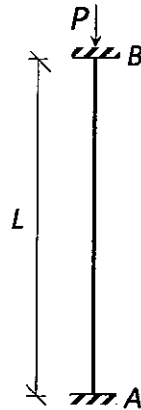

2. A composite section shown below is made up of a steel pipe ( $d_3=100$  mm,  $d_2=90$  mm,  $E_s=200$  GPa) with a plastic liner ( $d_1=80$  mm,  $E_p=4$  GPa). Allowable stresses in steel and plastic are 248.2 MPa and 5 MPa, respectively. What is the allowable bending moment for the composite section? (20%)

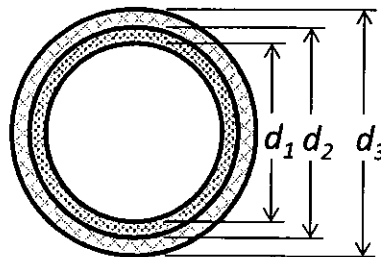

【可使用計算機】\*作答前請先核對試題、答案卷(試卷)與准考證之所組別與考科是否相符!!

3. The forces and couples shown below are applied to two screws as a piece of sheet metal is fastened to a block of wood.

- (1) Determine the equivalent force-couple system at point  $O$ . (10%)
- (2) Reduce the system to a wrench. (10%)
- (3) Determine the line of action of the wrench. (5%)

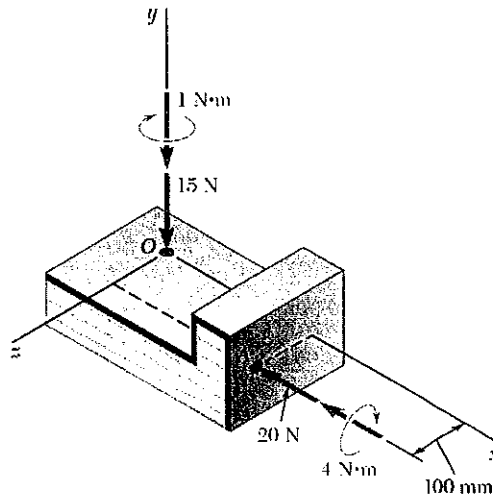

4. Knowing that  $d_C = 3m$ , determine the followings:

- (1) The reaction at  $E$ . (15%)
- (2) The distances  $d_B$  and  $d_D$ . (10%)

