

參考用

1. Which of the following systems is stable .(20%)

- (1) $s^4 - 6s^3 - s^2 - 17s - 6 = 0$
- (2) $s^3 - 4s^2 + 6s + 100 = 0$
- (3) $s^4 + s^3 + 2s^2 + 10s + 8 = 0$
- (4) $s^5 + s^4 + 2s^3 + s + 5 = 0$
- (5) $s^5 + s^4 + 2s^3 + s^2 + s + k = 0$
- (6) $s^3 + 4s^2 + 6s + 6 = 0$

2. Consider the feedback control system in the following Fig.1.

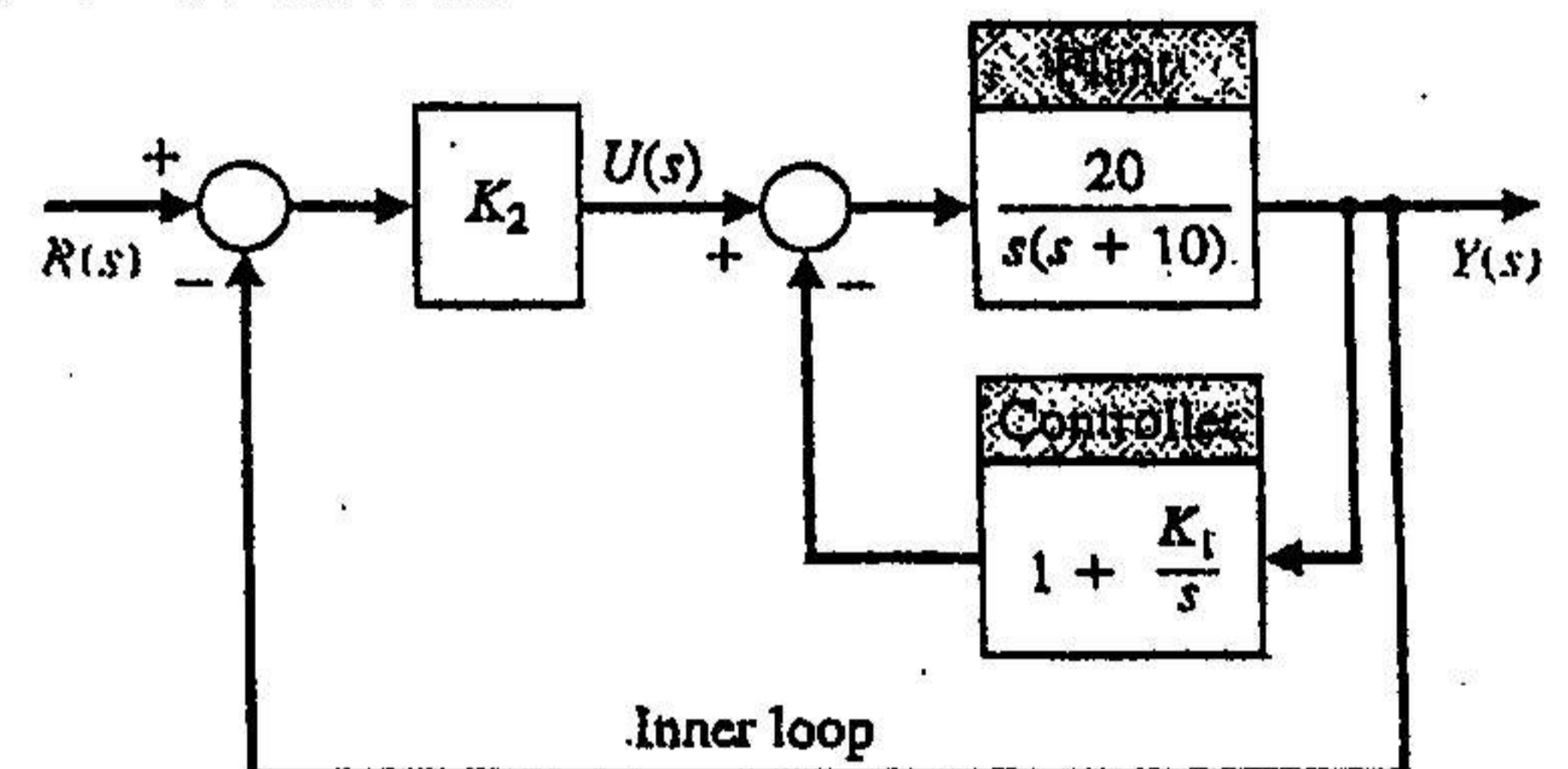

Fig.1

(1) Find the range of K_1 leading to a stable inner loop ($\frac{Y(s)}{U(s)}$) (10%)

(2) Find the range of K_2 such that the closed-loop system

$$T(s) = \frac{Y(s)}{R(s)} \text{ is stable (10\%)}$$

3. Given the functional block diagram Fig.2,

find values of the parameters k and a so that the steady-state error to a unit step input is zero. (20%)

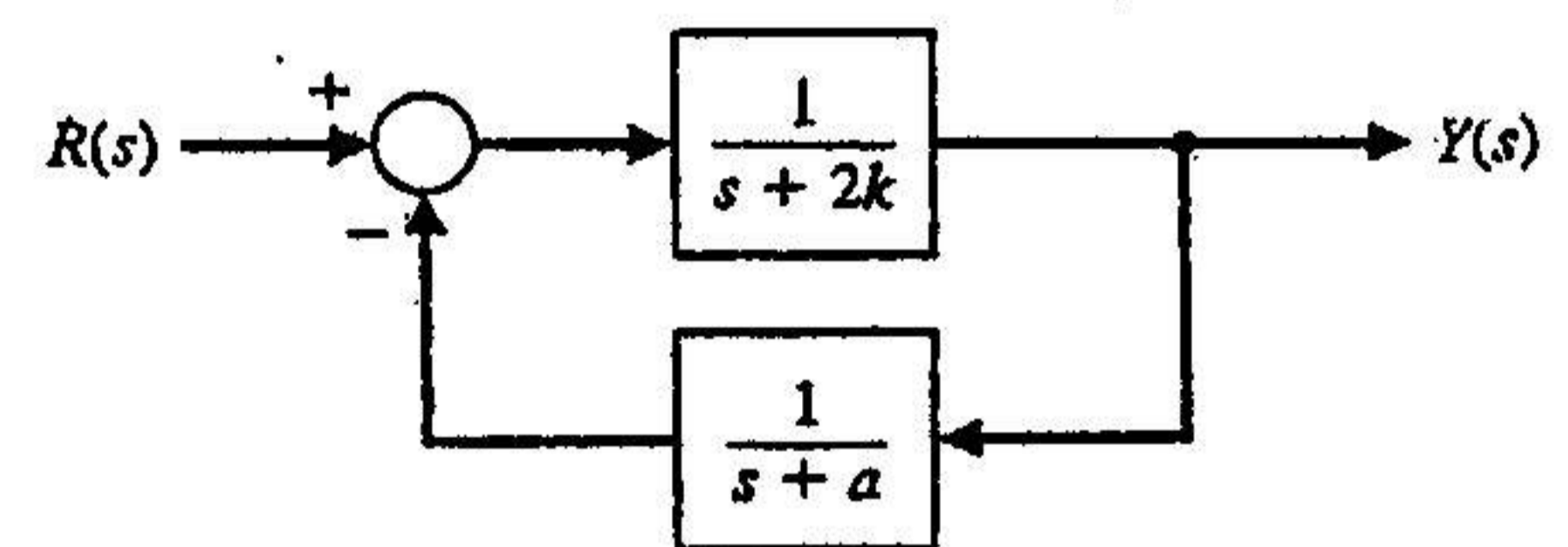

Fig.2

4. A two-mass system is shown in Fig.3, find the matrix differential equation when the output variable is $y_2(t)$. (20%)

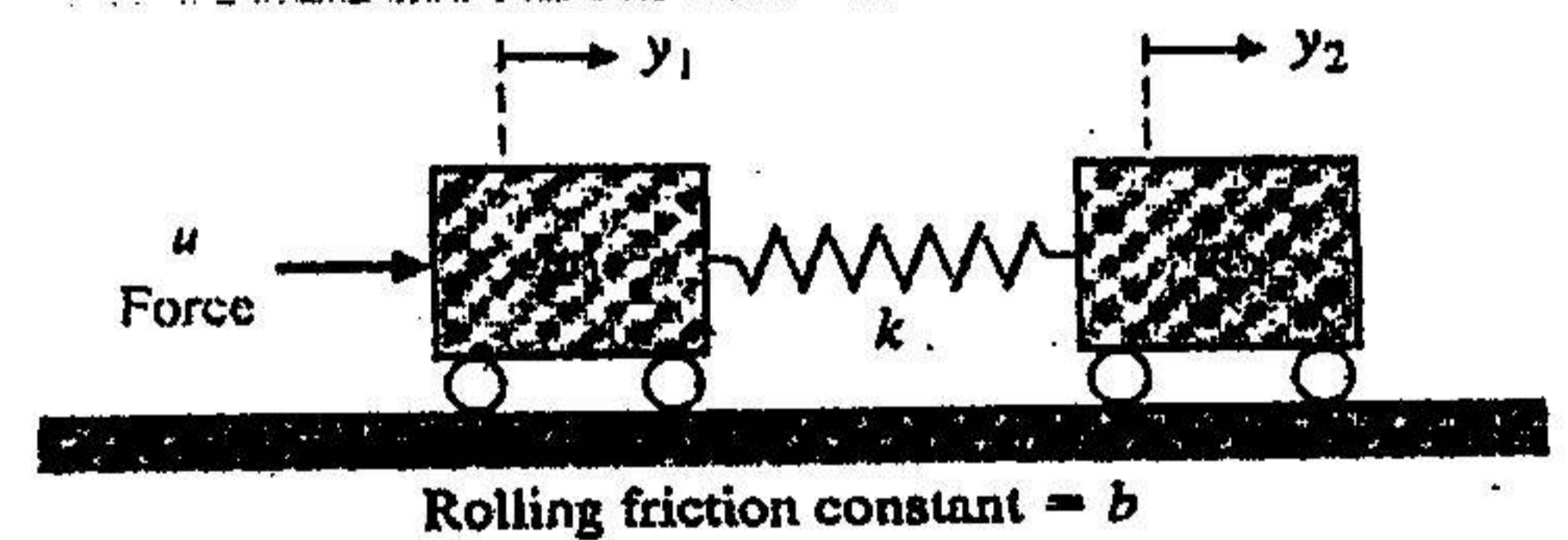

Fig.3

5. Obtain the closed-loop transfer function $T(s) = \frac{Y(s)}{R(s)}$ for the system of Fig.4.

(20%)

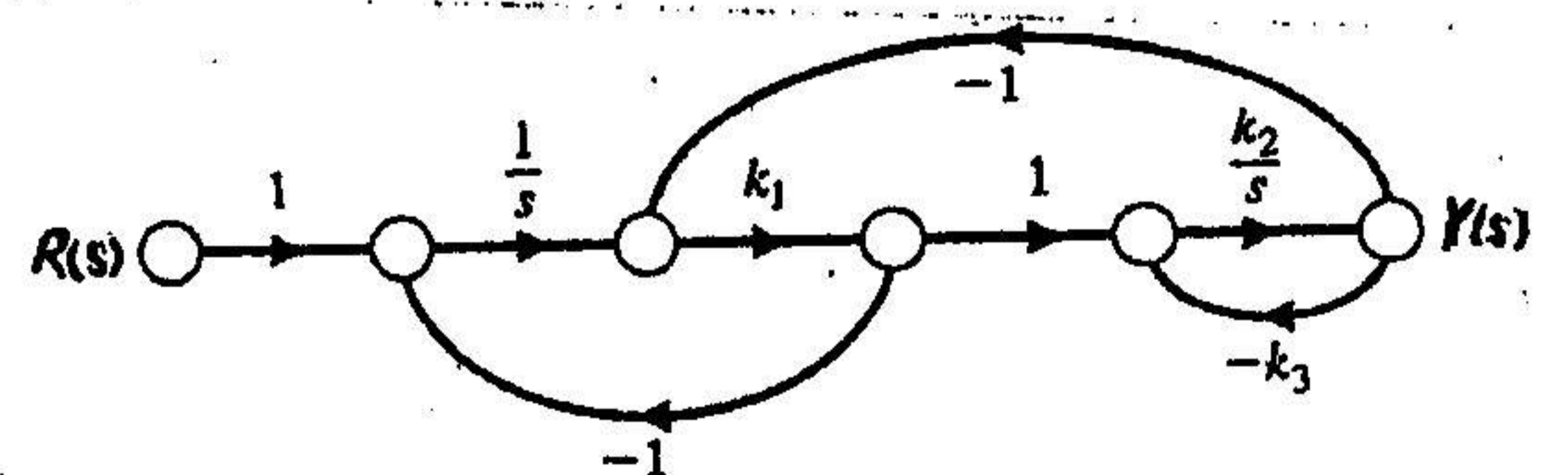

Fig.4