

系別：機械與機電工程學系

科目：材 料 力 學

A

准帶項目請打「V」	
<input checked="" type="checkbox"/>	簡單型計算機

本試題共 7 頁， 大題

1. A step shaft is supported at each end by thrust bearing, as shown in figure below. A force, $F = 500 \text{ lb}$, is applied at the step (point B) as shown. Determine the stress in each section of the shaft. The material is steel ($E = 30 \times 10^6 \text{ lb/in}^2$). (25%)

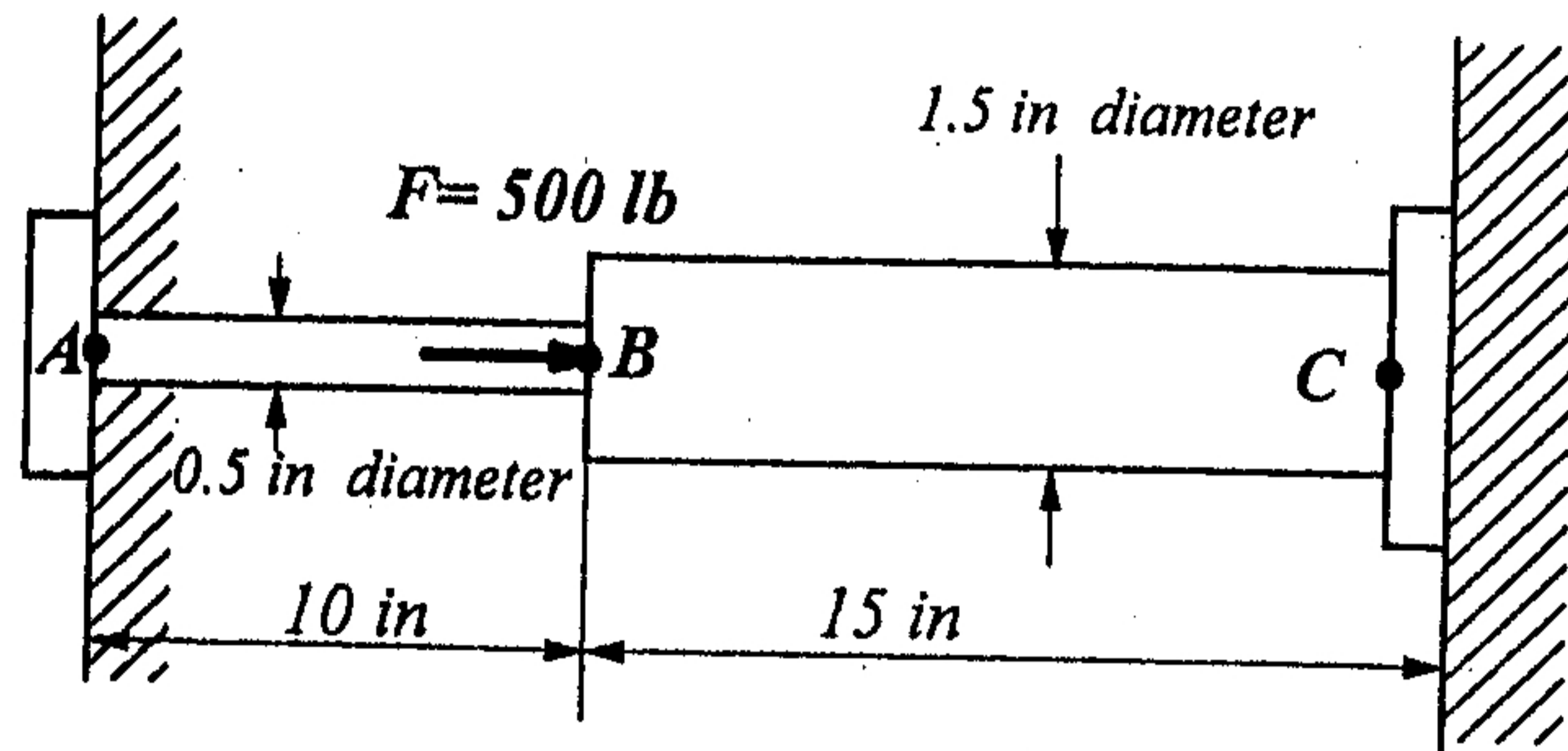

2. A step shaft (shown below) transmits a torque of 3000 lb-in. Determine the maximum shear stress and the relative angle of twist between surfaces located at point A and D ($E = 30 \times 10^6 \text{ lb/in}^2$, $\nu = 0.3$) (25%)

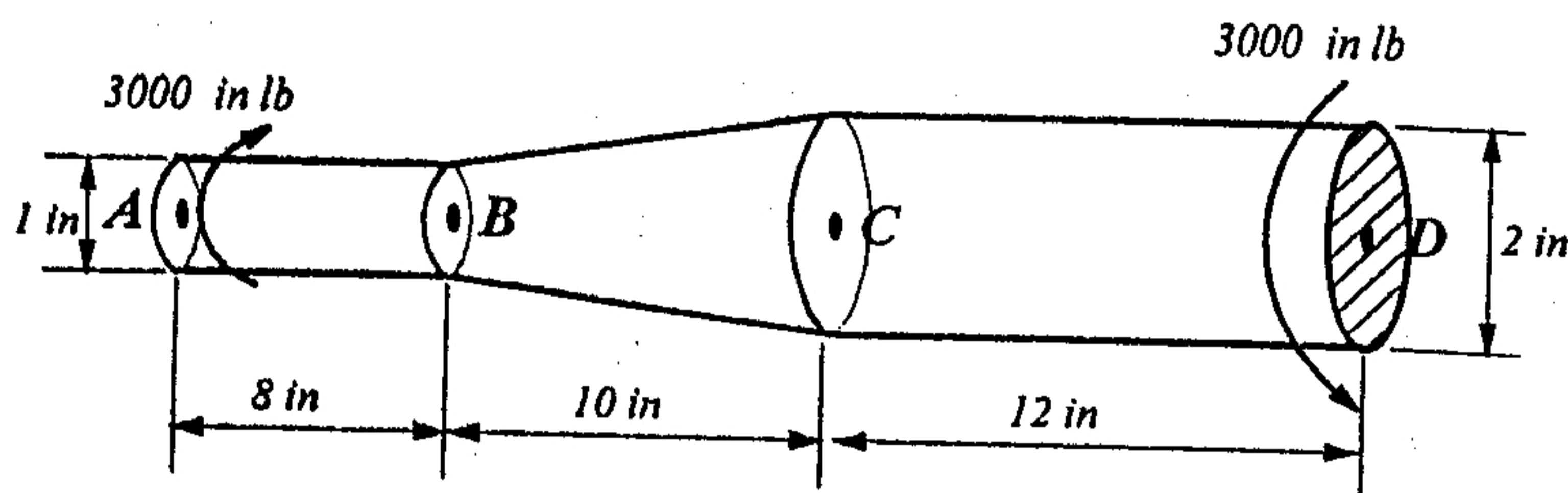

3. Determine (a) the distance a for which the maximum absolute value of the bending moment in the beam is as small as possible, (b) the corresponding maximum normal stress due to bending. (Hint: Draw the bending-moment diagram and then equate the absolute values of the largest positive and negative bending moments obtained.) (25%)

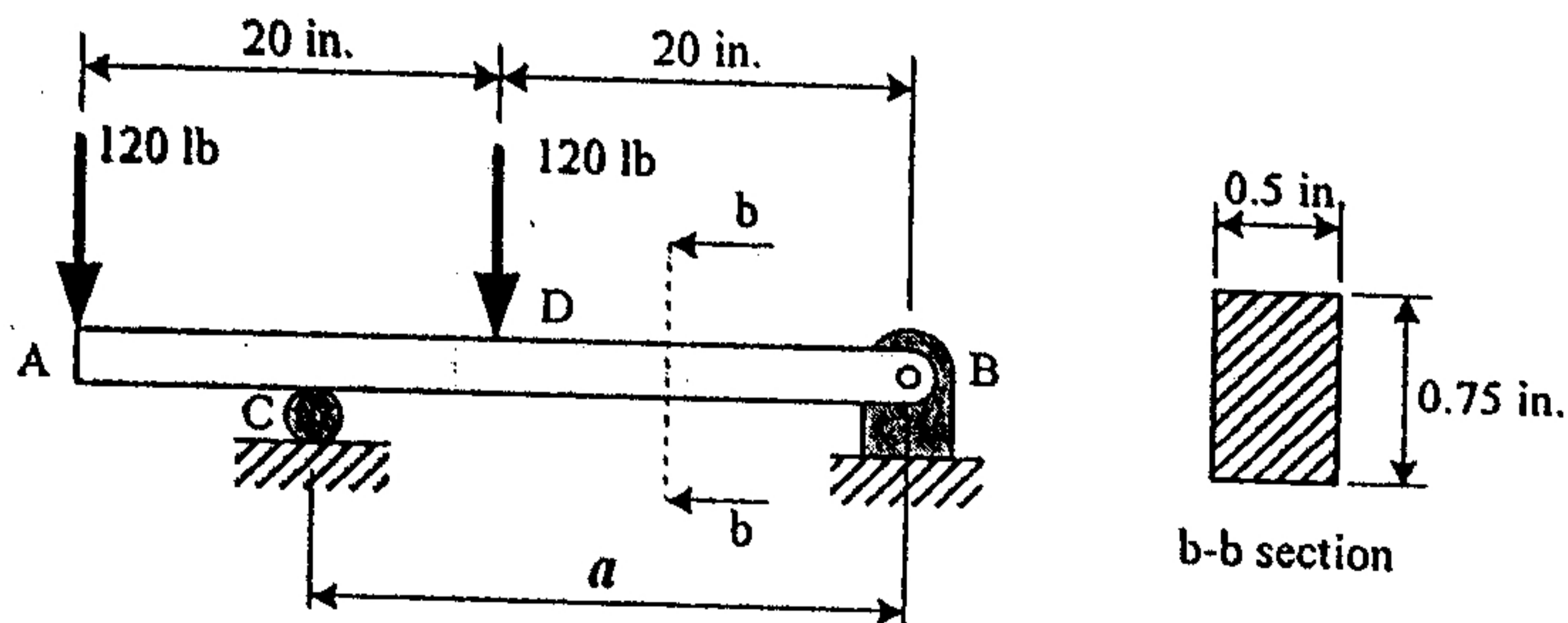

本試題雙面印製

◀ 注意背面尚有試題 ▶

淡江大學 97 學年度碩士班招生考試試題

61-2

系別：機械與機電工程學系

科目：材 料 力 學

准帶項目請打「V」	
✓	簡單型計算機

本試題共 2 頁， 大題

4. The steel pipe AB has a 102-mm outer diameter and a 6-mm wall thickness. Knowing that arm CD is rigidly attached to the pipe, determine the principal stresses and the maximum shearing stress at point K. (25%)

