

1. The position of stylus tip A is controlled by the robot shown. In the position shown the stylus moves at a constant speed $u=200\text{mm/s}$ relative to the solenoid BC. At the same time, arm CD rotates at the constant rate $\omega_2 = 2.0\text{ rad/s}$ with respect to component DEG. Knowing that the entire robot rotates about the x axis at the constant rate $\omega_1 = 1.5\text{ rad/s}$, determine (a) the velocity of A, (b) the acceleration of A. (20%) *Fig. (-)*
2. Three spheres, each of mass m , can slide freely on frictionless, horizontal surface. Spheres A and B are attached to an inextensible, inelastic cord of length L and are at rest in the position shown when sphere B is struck squarely by sphere C which is moving to the right with a velocity V_0 . Knowing that the cord is taut when sphere C and assuming perfectly elastic impact between B and C, and thus conservation of energy for the entire system, determine the velocity of each sphere immediately after impact. Furthermore, sphere A and B are not taut by the cord when sphere C strikes sphere B and C, determine the velocity of each sphere immediately after the cord becomes taut. (20%) *Fig. (=)*
3. A 4 kg uniform cylinder A can roll without sliding on a 6 kg cart C and is attached to a spring AB of constant $k=150\text{ N/m}$ as shown. The system is released from rest when the spring is stretched 15 mm. Neglecting wheel friction, determine the velocity of the cart and the angular velocity of the cylinder when the spring first reaches its undeformed state. (20%) *Fig. (=)*
4. Two 100 mm rods A and B, each of mass 400g, are welded to shaft CD which is supported by bearings at C and D. If a couple M of magnitude equal to 8 N-m is applied to the shaft, determine the components of the dynamic reactions at C and D at the instant when the shaft has reached an angular velocity at 1000 rpm. Neglect the moment of inertia of the shaft itself. (20%) *Fig. (四)*
5. Find the horizontal and vertical components of the reaction of pin D on the member AG of the frame as shown. Neglect the weight of all members. (20%) *Fig. (二)*

(背面仍有題目,請繼續作答)

本試題是否可以使用計算機： 可使用， 不可使用 (請命題老師勾選)

考試日期：0301 節次：1

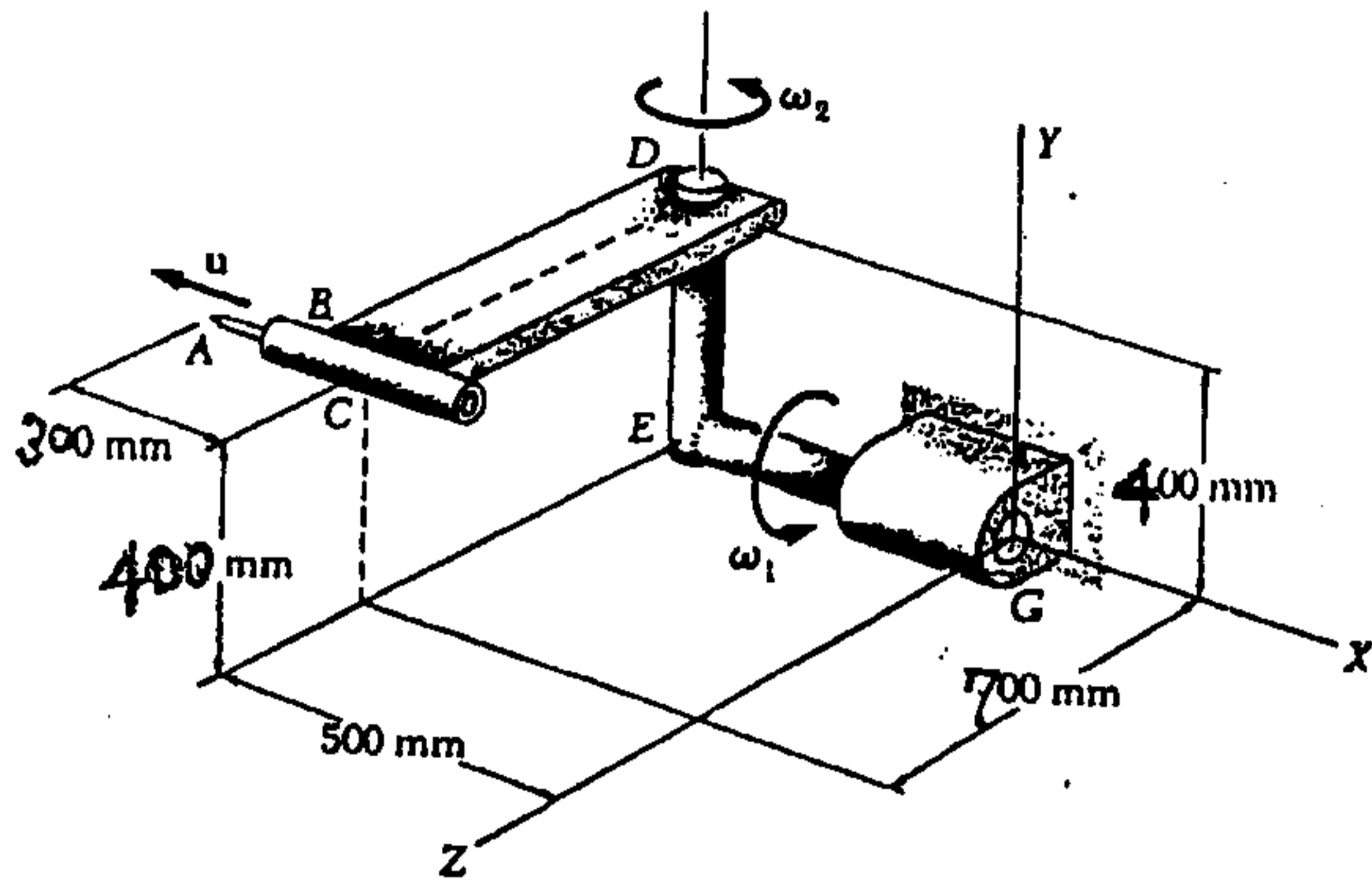

Fig. (一)

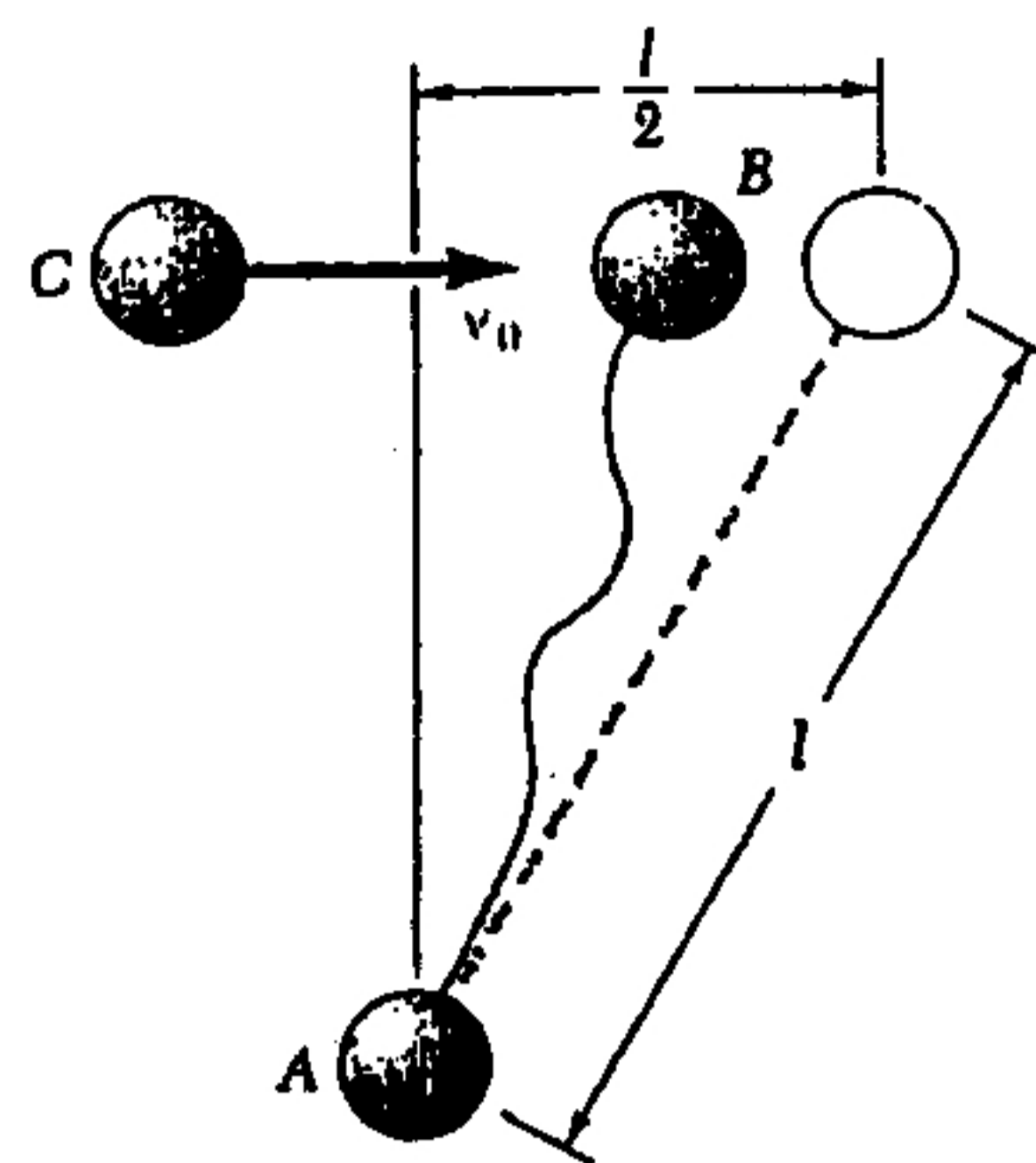

Fig. (二)

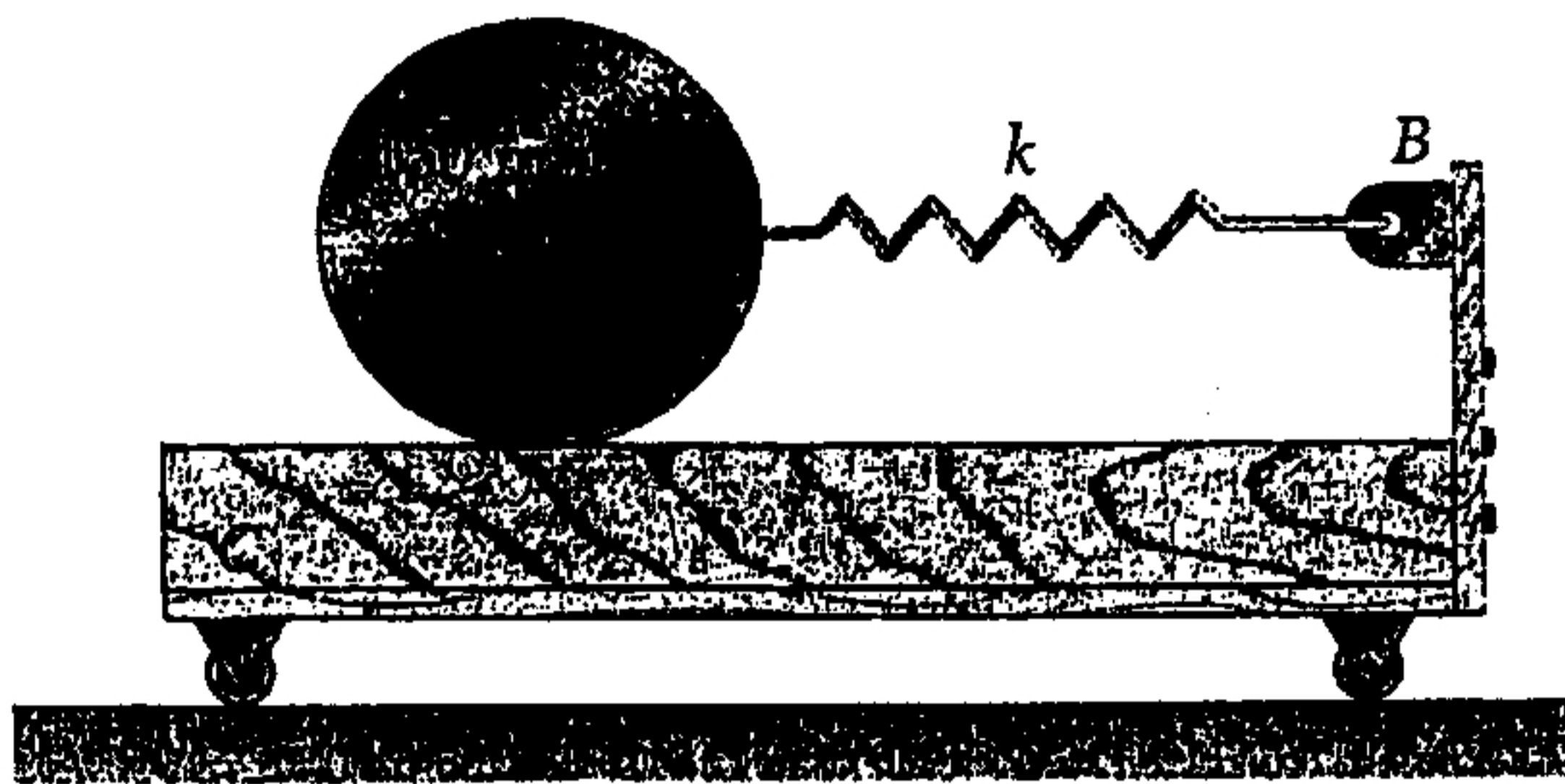

Fig. (三)

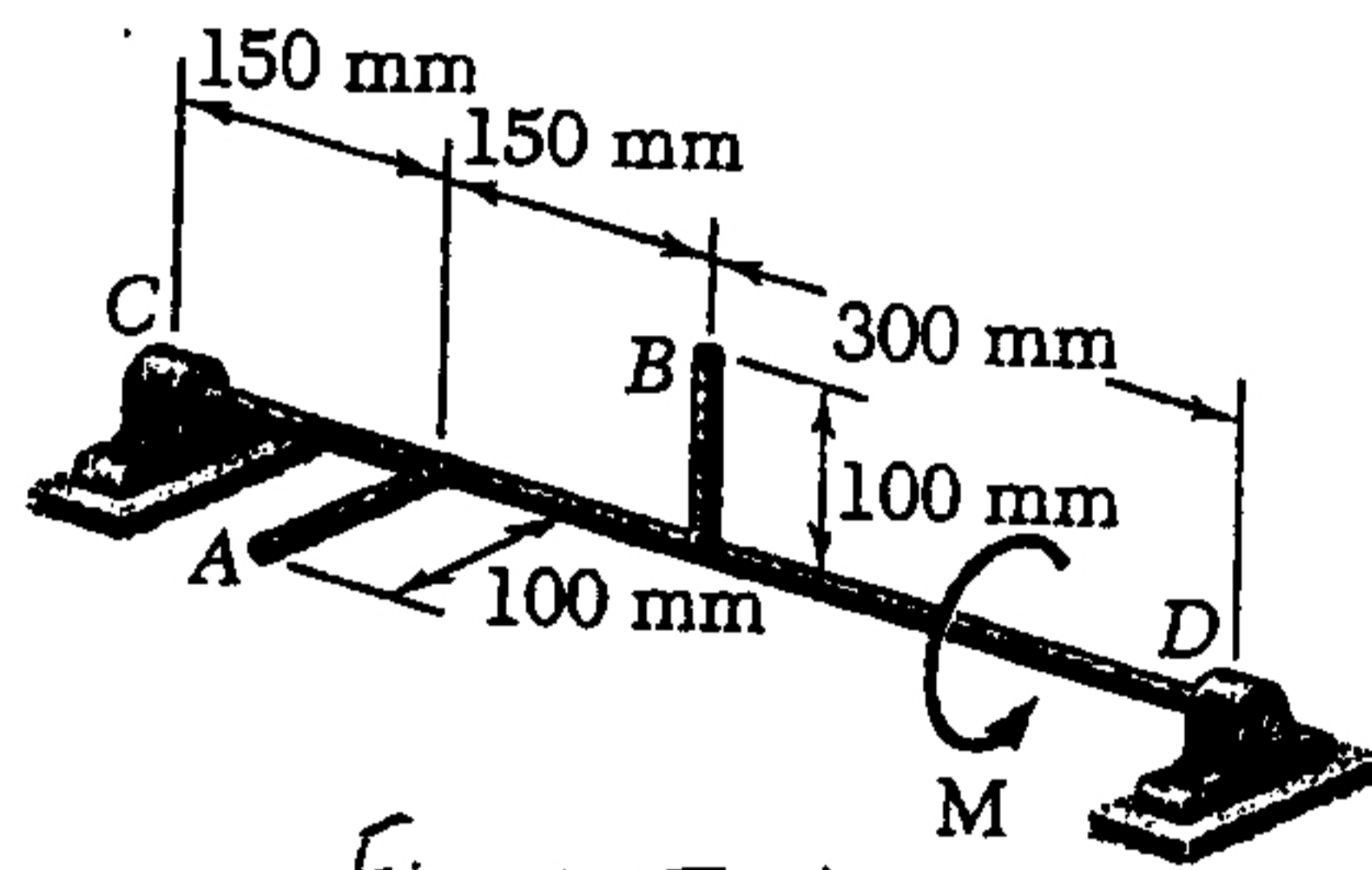

Fig. (四)

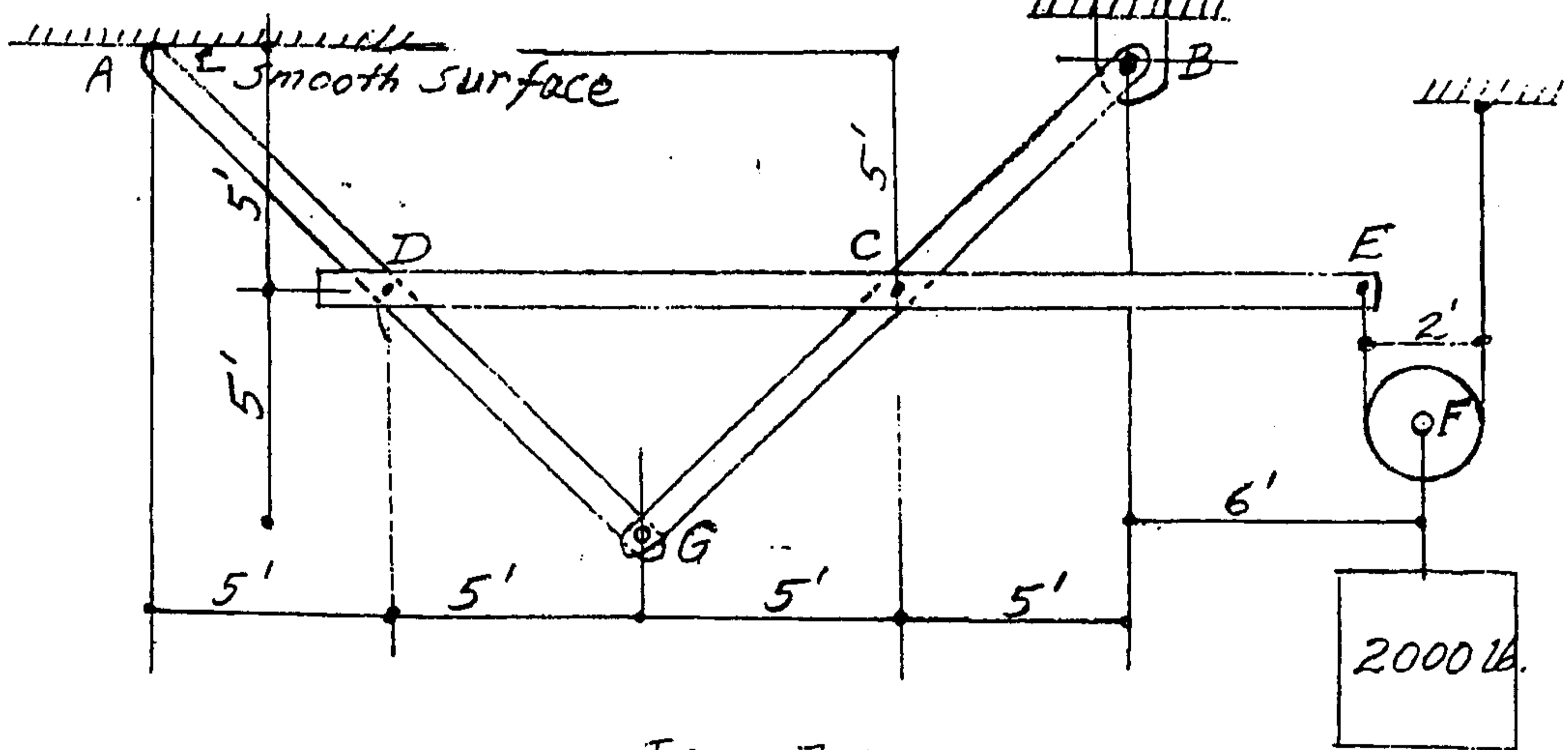

Fig. (五)